

### Features

- Non-fragmenting design solid metal cross-scored disk
- Operating pressures to 90% of the disk's marked burst pressure
- Suitable for gas service only
- Disk is scored on the vent side to minimize the effect of product build up on the process side
- Burst ratings 20 to 1000 psig
- Sizes 1" thru 24"
- Temperature ratings to 900°F (482°C)
- Materials of construction: 316SS, Inconel, Monel, Nickel, or Aluminum
- 3-dimensional stainless steel tag is standard
- No Vacuum Support required
- Extended cycle life: withstands positive-to-negative cycling
- ASME UD marking available
- Use alone or combine with relief valves
- Unique notches in disk O.D. ensures proper mounting into SR7A Disk Holder



### Safety Relief Valve Protection

SRA Series Disks mounted under the valve isolate working parts from hostile environments.

### Option

**Liners** TFE liners are available to provide protection from corrosive media if required. Refer to Table 1 for maximum temperature ratings for disks and liners.

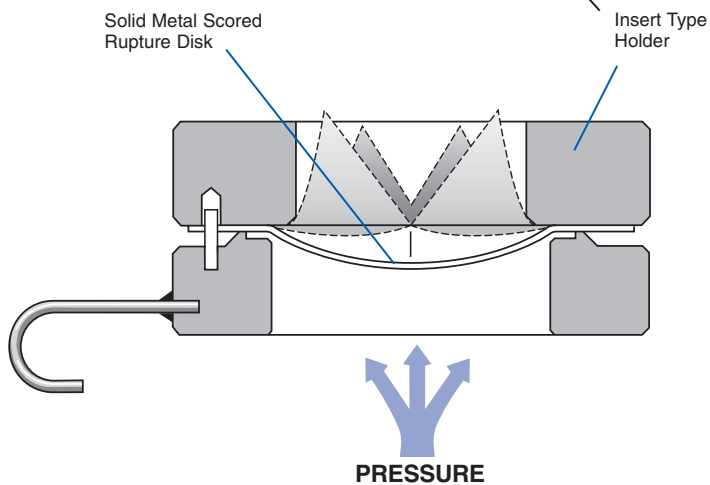

SRA Series Disks mount with the convex surface facing the process media. As pressure increases above the recommended operating ratio, the compressive stress in the disk material increases until a point of instability is reached. At that point the disk begins to buckle. It tears along the score lines as it reverses, which initiates the complete rupture of the disk.

**Table 1 – SRA Series Minimum and Maximum Pressure Ratings –  
psig (bar) @72° F (22°C)**

Disk Size	Disk Material Burst Pressure Range									
	Aluminum <sup>1</sup>		Nickel <sup>2</sup>		Monel		Inconel		316SS	
	min.	max.	min.	max.	min.	max.	min.	max.	min.	max.
1"	75	125	92	1000	122	1000	141	1000	221	1000
25 mm	5.17	8.62	6.34	68.97	8.41	68.97	9.72	68.97	15.24	68.97
1-1/2"	54	90	81	1000	98	1000	98	1000	234	1000
40 mm	3.72	6.21	5.59	68.97	6.76	68.97	6.76	68.97	16.14	68.97
2"	45	75	60	1000	83	1000	83	1000	188	1000
50 mm	3.10	5.17	4.14	68.97	5.72	68.97	5.72	68.97	12.97	68.97
3"	36	60	55	1000	65	1000	66	1000	154	1000
80 mm	2.48	4.14	3.79	68.97	4.48	68.97	4.55	68.97	10.62	68.97
4"	30	50	48	800	55	800	54	800	122	800
100 mm	2.07	3.45	3.31	55.17	3.79	55.17	3.72	55.17	8.41	55.17
6"	24	40	35	800	44	800	47	800	94	800
150 mm	1.66	2.76	2.41	55.17	3.03	55.17	3.24	55.17	6.48	55.17
8"	▲		33	700	41	700	44	700	▲	
200 mm	▲		2.28	48.28	2.83	48.28	3.03	48.28	▲	
Max. Temp.	250°F (121°C)		750°F (399°C)		800°F (427°C)		900°F (482°C)		900°F (482°C)	

▲ For larger sizes or sizes not shown, contact ZOOK

<sup>1</sup> Aluminum not available with UD marking

<sup>2</sup> ASME minimum available burst pressures

**Table 1 – notes**

- Minimum rating will support full vacuum without additional vacuum support
- Alternate materials and lower burst ratings are available on request. Contact ZOOK for more information

# SR7A Series Disk Holder

**Features**

- Insert type Rupture Disk Holder – designed exclusively for use with the SRA Series Rupture Disk
- The SR7A Holder and Rupture Disk are assembled using safety designed side clips
- Standard materials of construction: 316SS and carbon steel. Other materials available upon request
- Permanently attached stainless steel nameplates are standard. Nameplates indicate flow direction and provide visual verification that holder assembly is properly oriented in the piping system
- Holder supplied with alignment pins and J-hook as standard

**Available options include:**

Gauge tap; nipple and tee; excess flow valve; pressure gauge; special facings and coatings



Holder Dimensions  
Inches (mm)

Nominal Size	ASME B16.5 Flange Classes ■		Height
	Class 150 O.D.	Class 300/600 ▲ O.D.	
1"	2-1/2"	2-3/4"	1-1/2"
25 mm	63.50	69.85	38.10
1-1/2"	3-1/4"	3-5/8"	1-5/8"
40 mm	82.55	92.08	41.28
2"	4"	4-1/4"	1-3/4"
50 mm	101.60	107.95	44.45
3"	5-1/4"	5-3/4"	2-1/8"
80 mm	133.35	146.05	53.98
4"	6-3/4"	7" ▲	2-7/8"
100 mm	171.45	177.80	73.03
6"	8-5/8"	9-3/4" ▲	3-11/16"
150 mm	219.08	247.65	93.68
8"	10-7/8"	12" ▲	3-13/16"
200 mm	276.23	304.80	96.85

NA Not Available

■ Available to fit DIN and JIS flanges

▲ Contact ZOOK for flange class rating 600

**Manufacturing Range  
Burst Tolerance @ 72°F (22°C)**

Specified Burst Pressure Rating psig (bar)	Available Manufacturing Ranges	Burst Tolerance
40 (2.76) and below	0%, -5%, -10%	± 2 psig (0.14)
Above 40 (2.76)	0%, -5%, -10%	± 5%

**Notes:**

- 0% manufacturing range is not available in all materials
- Burst tolerances are the maximum expected variation from the disk's marked burst pressure

**TFE liner may be added to provide additional protection against corrosive media**

Requirements/Limitations when TFE liner is added:

1. Max. temperature of 500°F (260°C) – Limitation of liner material
2. Liner may be applied to all ratings. Contact ZOOK if liner is required on both sides of rupture disk



**ZOOK Enterprises, LLC**  
16809 Park Circle Drive  
Chagrin Falls, OH 44022 U.S.A.  
Toll Free 800.543.1043  
Phone 440.543.1010  
Fax 440.543.4930  
E-mail sales@zook.cc

**ZOOK Canada, Inc.**  
4400 South Service Road  
Burlington, ON Can. L7L 5R8  
Toll Free 800.370.6057  
Phone 905.681.2885  
Fax 905.681.8838  
E-mail sales.canada@zook.cc

**ZOOK Europe, LTD.**  
Unit 1.14, Great House Waterside Business Park  
Redwall Close, Rotherham Road  
Dinnington, Sheffield UK. S25 3QA  
Phone 0044 (0) 1909 560999  
Fax 0044 (0) 1909 560860  
E-mail zookeurope@zook.cc



visit us on the web at [www.zook.cc](http://www.zook.cc)