

BA Series Rupture Disk Burst Sensor

Over pressure indication for rupture disk or relief valve applications

When a pressure surge causes a relief valve to open, it also destroys the rupture disk under the valve. This leaves the valve vulnerable to chemical attack. The **BA Burst Sensor** reduces this threat by constantly monitoring the disk. When connected to an electrical alarm, the **BA Burst Sensor** alerts personnel to take immediate action to protect system components from further damage.

Operation

When a disk bursts, flow pulls one end of the **BA Burst Sensor's** conductor out of its retaining slot and opens the electrical circuit. The **BA Burst Sensor** can be reset by re-inserting the conductor into the retaining slot.

Features

- Re-useable
- Sizes 1" thru 24"
- Electrically conductive
- Installs on vent side of the disk holder or alone
- Requires minimal flange face-to-face clearance
- Adapts to virtually all makes/types of rupture disks, including Graphite types
- Fits easily into existing pipe systems
- Optional leak detection (BA-LD) for damaged rupture disks or fugitive emissions from relief valves or atmospheric designed systems
- BA-LD functions with or without a rupture disk



BA Operating Limits	
Max. Temperature.....	700°F
Max. Continuous Temp	400°F
Max. Voltage.....	24 VDC
Max. Current.....	20 mA

Specifications

Disk Size	Minimum Burst Pressure* PSI @ 72°F (22°C)	Nominal Indicator Thickness	Thickness with Optional LD
1" - 2"	5	3/16"	1/4"
3"	3		
4"	2		
6" - 24"	1		

*Applies to both BA and BA-LD

Ordering Information

When ordering BA Series, specify: flange size, flange series, relieving pressure or pressure relief device, and coincident temperature

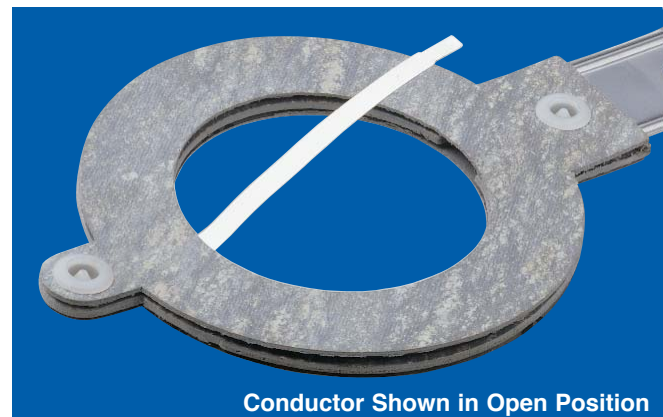

Conductor Shown in Open Position

Note: BA and BA-LD is considered a simple device, therefore, approval is not required. Installation must be in accordance with ANSI/ISA RP12.6 and the NEC (ANSI/NFPA 70)

Optional Leak Detector (LD) for BA Burst Sensor

For optional leak detection specify BA-LD. The LD is a TFE seal affixed between two gaskets. When installed on the BA a build-up in pressure causes the BA Burst Sensor Conductor to pull out of its retaining slot and opens the electrical circuit.

Note: Max. Temperature of 500°F (260°C) Limitation of liner material

The LD is always installed on the pressure side of the BA.



Optional Leak Detection (LD) with conductor shown in OPEN position

BA with Conductor shown in OPEN position

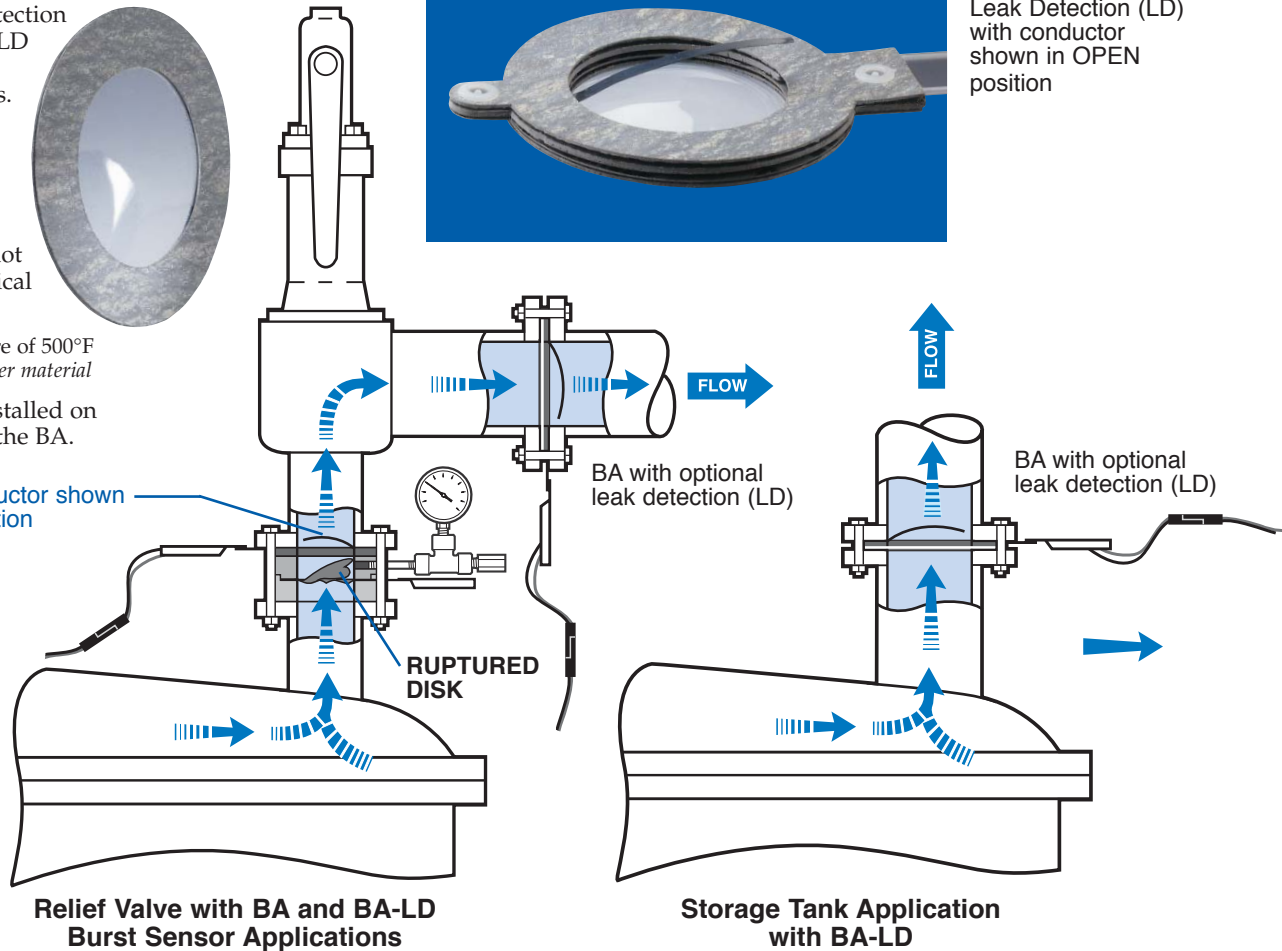

MONITOR

The BA Burst Sensor works with ZOOK ZM2 Alarm Monitor or any other monitoring system. Consult ZOOK for additional information.

The monitor wired to the BA Burst Sensor will be activated providing immediate local or remote warning of a ruptured disk. The ZM2 monitor allows output to control pumps, valves, and other equipment which may be activated to control or shutdown a process.

CAUTION

The BA Burst Sensor is an electrical device suitable for use in hazardous locations (Class I, II, and III, Division 1 and 2, Group A thru G) provided that it is used with an approved intrinsically safe electrical alarm monitor.

For services involving highly electrically conductive fluids, consult the ZOOK factory for this type of application.

CLASS I, II, III
DIVISION 1
GROUPS A,B,C,D,E,F,G

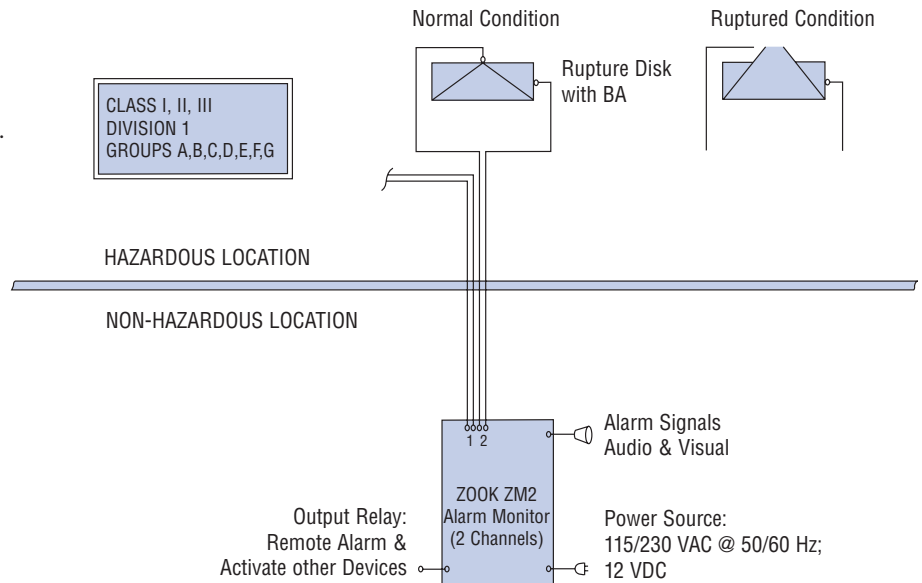

ZOOK USA
16809 Park Circle Drive
Chagrin Falls, OH 44022
Phone **440.543.1010**
Toll Free **800.543.1043**
Fax **440.543.4930**
E-Mail **sales@zook.cc**

PROCESS EQUIP., INC.
4400 South Service Road
Burlington, ON Can. L7L 5R8
Phone **905.681.2885**
Toll Free **800.370.6057**
Fax **905.681.8838**
E-Mail **sales@proquipdisk.com**

ZOOK EUROPE LTD
Unit 1.14, Great House Waterside Business Park
Redwall Close, Rotherham Road
Dinnington, Sheffield UK. S25 3QA
Phone **0044 (0) 1909 560999**
Fax **0044 (0) 1909 560860**
E-Mail **zookeurope@zook.cc**

Servicing Rupture Disk needs worldwide from manufacturing facilities located in 3 countries on 2 continents

24.7.365

visit us on the web at www.zook.cc