

TWO-WAY Type

dual rated to protect against two different pressures in opposite directions

- Applications include protection of storage tanks against both excess vacuum and overpressure when single vessel entry is required
- Sizes 1-1/2" thru 24" diameters
- Designed to fit ASME B16.5 Class 150 flanges. Contact ZOOK for ASME B16.5 Class 300 flanges
- Burst ratings 0.25 to 1000 psig or higher
- 0% manufacturing range
- Operating pressures to 90% of the disk's marked burst pressure (Contact ZOOK for operating ratio for burst pressures below 40 psig)
- Temperature ratings -290°F to +430°F (-179°C to +221°C). Contact ZOOK for higher temperature ratings. The specified temperature shall be at the disk location at the time when the disk is expected to rupture
- Optional liner available on flat side of disk to extend corrosion resistance
- Carbon steel armor standard, 316SS optional
- Furnished complete with TFE gaskets attached. Other gasket materials are available
- Generally a minimum differential of 10 psi is required between burst ratings. Contact ZOOK for other burst rating combinations

Specifications – ASME B16.5 Class 150

Nominal Disk Sizes	Disk Dimensions			Minimum Burst Rating psig
	Diameter		Thickness*	
	I.D.	O.D.		
1-1/2"	1-1/2"	3-1/4"	1-1/8"	7
2"	2"	4"	1-1/8"	3
3"	3"	5-1/4"	1-1/8"	2
4"	4"	6-3/4"	1-1/8"	1.5
6"	6"	8-5/8"	1-1/8"	1
8"	8"	10-7/8"	1-3/8"	0.50
10"	10"	13-1/4"	1-3/4"	0.25
12"	12"	16"	2-1/4"	0.25
14"	13-1/4"	17-5/8"	2-1/2"	0.25
16"	15-1/4"	20-1/8"	2-3/4"	0.25
18"	17-1/4"	21-1/2"	3"	0.25
20"	19-1/4"	23-3/4"	3-1/4"	0.25
24"	23-1/4"	28-1/8"	3-1/4"	0.25

*Disk thickness includes all gaskets.
Contact ZOOK for flow area (MNFA)

Technical Data

Testing Method

Standard disks are rated at the specified burst pressure without applying a Manufacturing Design Range (MDR) by bursting two or more disks to establish burst accuracy. Where higher than room temperature (+40°F to +100°F) service is specified, oven tests can be conducted, or disks can be room temperature tested with compensation made using a temperature curve developed specifically for our disks. (These disks are designated *Chart Compensated Disks*.) *ASME disks* are tested at the specified coincident temperature.

ASME Code and Jurisdictional Regulations

Most jurisdictions require ASME Code compliance on Boiler and Pressure Vessel construction. All pressure vessels within the scope of the ASME Code Section VIII, Div. 1 shall be provided with pressure relief devices. It is the responsibility of the *user* to ensure that the required devices are properly installed prior to initial operation of the pressure vessels.

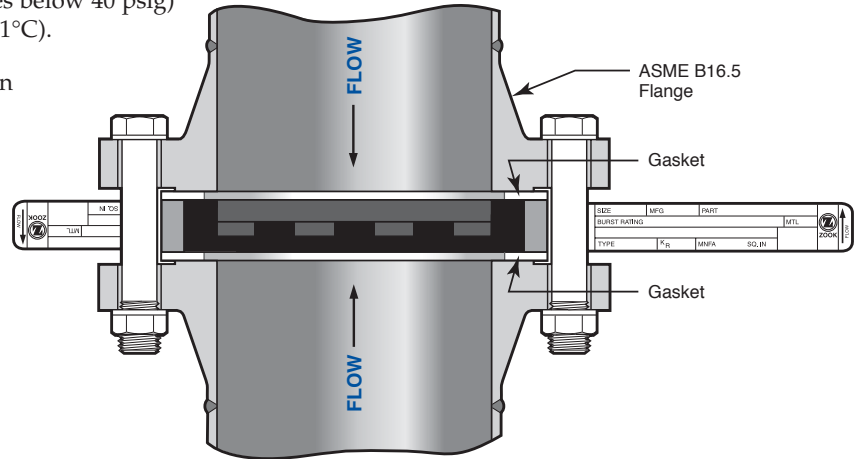

If company policy or jurisdictional regulation requires ASME Code compliance, the rupture disk devices used for pressure vessel overpressure protection shall bear the ASME Code UD symbol. The UD marking is the manufacturer's declaration that the device was manufactured in full compliance with the ASME Code.

Disks specified to ASME Code requirements are rated using a 0% MDR unless a special MDR is specified and agreed upon. 0% MDR disks are marked with the specified burst rating. Refer to the certified type for the flow resistance factors (K_f) and the Minimum Net Flow Area (MNFA).

Pressure Ratings and Burst Tolerances

Burst ratings range from 0.25 psig to above 1000 psig for sizes 1/2" thru 24". Refer to minimum and maximum values in tables provided for each disk. Standard burst tolerances are:

Pressure Rating psig @ 72°F (22°C)	Burst Tolerance
Above 40	±5%
15 to 40	±2.0 psi
5 to less than 15	±1.0 psi
Above 1 to less than 5	±0.75 psi
1 or less	+0.75 psi / -0

Contact ZOOK for tighter burst tolerance

Corrosion Resistance

Depending on the type of options, ZOOK Graphite rupture disks can be subjected to almost any corrosive with the exception of free fluorine. A reference guide with corrosion resistance information is available upon request for use when specifying ZOOK Graphite Rupture Disks. This guide offers compatibility with common corrosives. Where there is doubt about compatibility, a sample of ZOOK Enterprises graphite can be supplied on request for your onsite evaluation. Please contact the factory if you have any questions.